



RENEGADE
RUM
D I S T I L L E R Y

Renegade Single Cane Rum
Process Graphic

CANE

SUGAR CANE ONLY

6
VARITIES

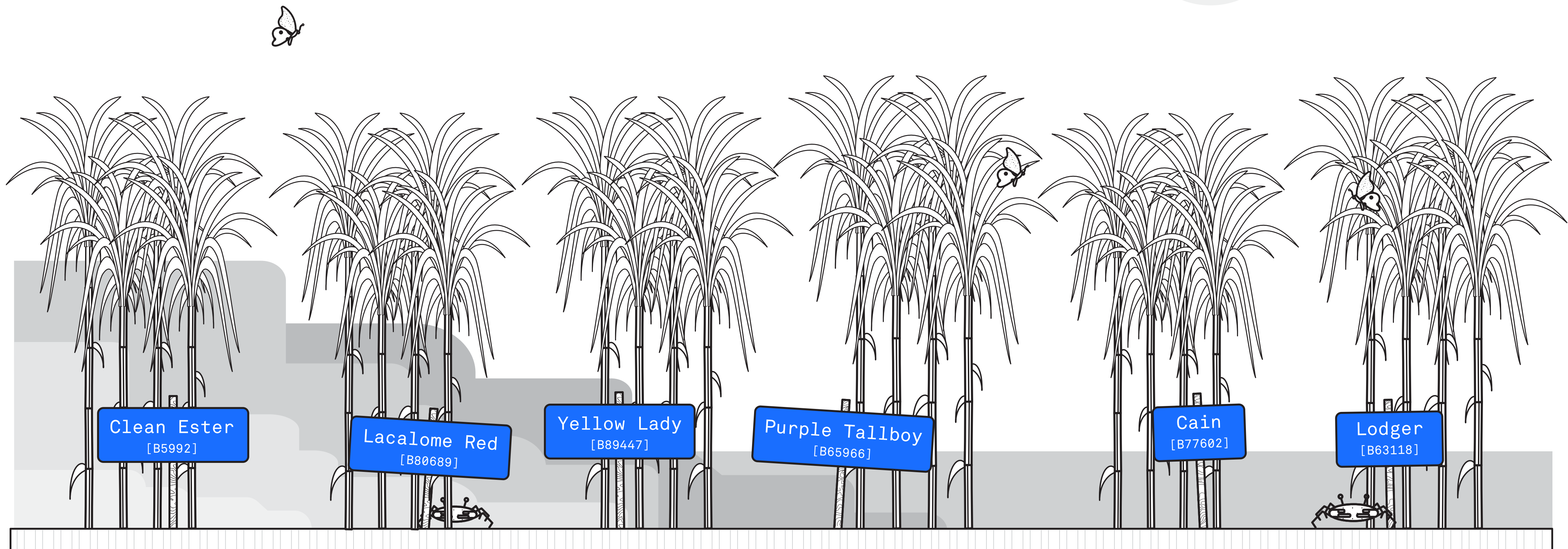

FARMS

FARMED BY



10
FARMS



WINDWARD ISLANDS

GRENADA
12.118°, -61.689°

SOUTH AMERICA

EQUATOR LINE

CARIBBEAN SEA

Grenada

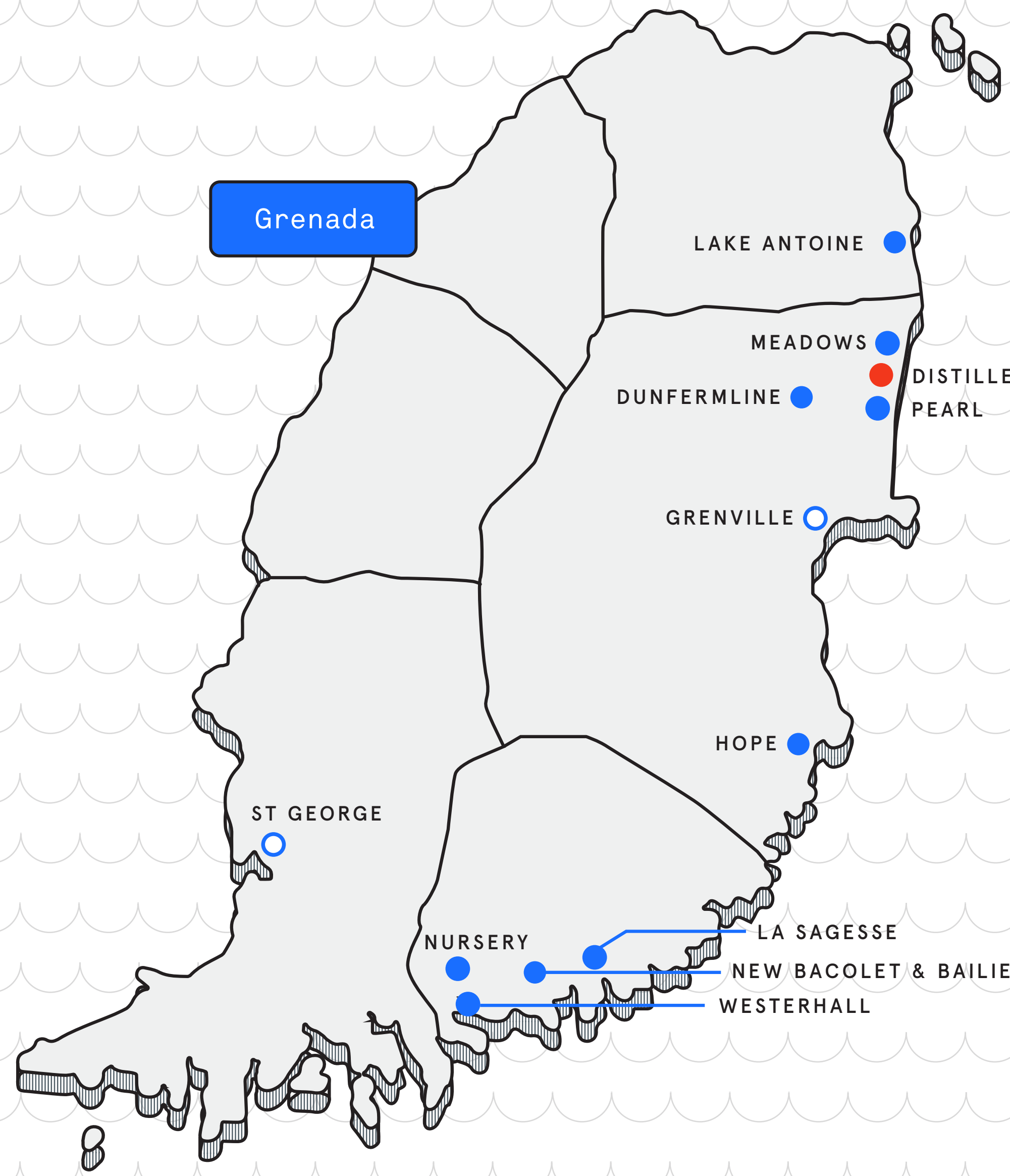

LAKE ANTOINE

MEADOWS

DUNFERMLINE

DISTILLERY

PEARL

GRENVILLE

HOPE

ST GEORGE

NURSERY

LA SAGESSE

NEW BACOLET & BAILIES BACOLET

WESTERHALL



NORTH EASTERLY
TRADE WINDS

ATLANTIC OCEAN

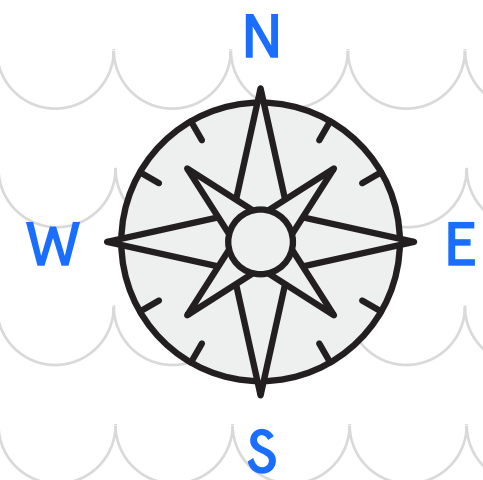

TERROIR

THE INTERACTION OF MICROCLIMATE, SOIL & PLACE ON CANE GROWTH – GIVES INDIVIDUAL CHARACTER

5
SOIL TYPES

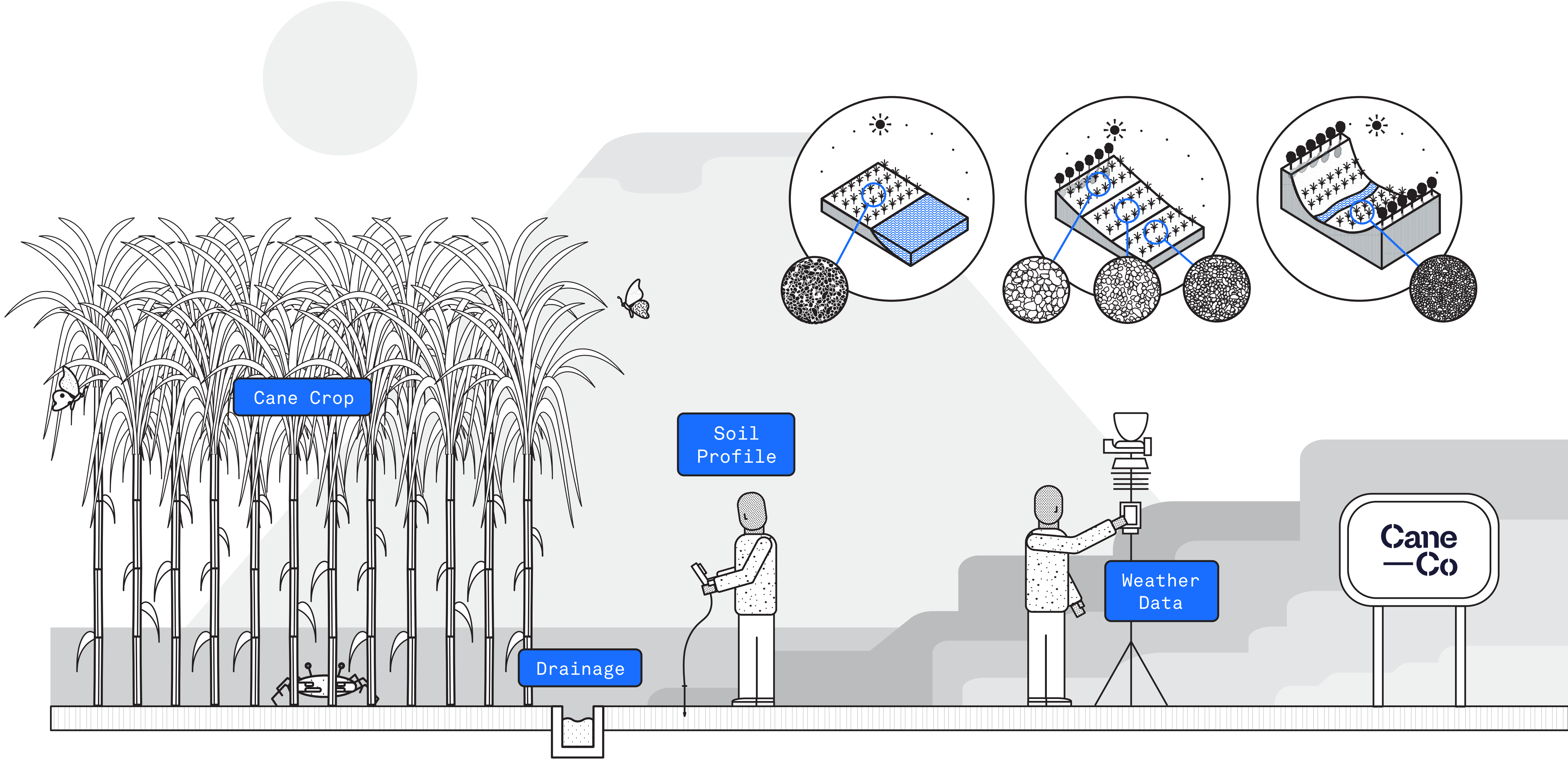

HARVEST

UNDULATING TOPOGRAPHY ALLOWS MECHANICAL CUTTING

1
FIELD PER
DAY

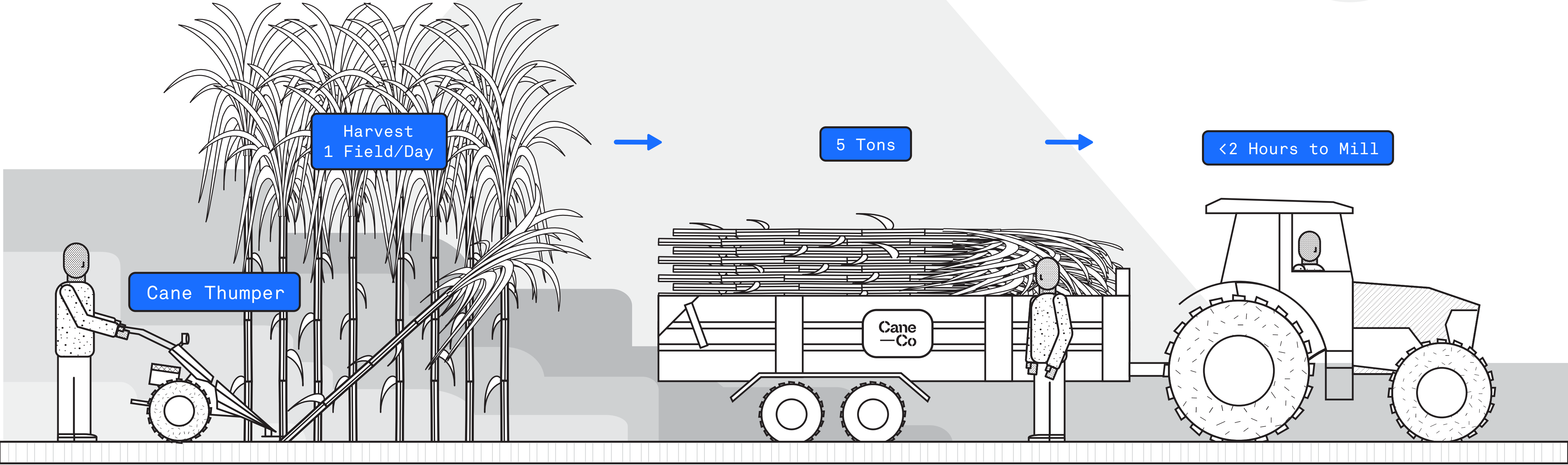
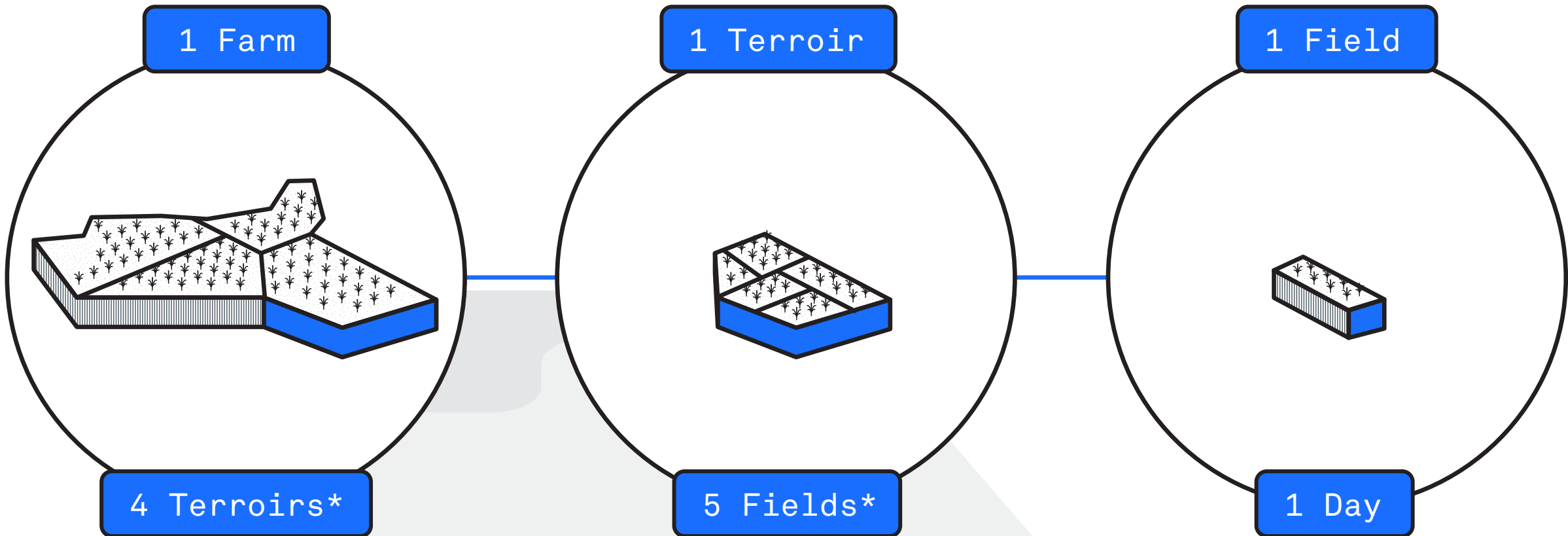

*Approximately

INTAKE

GENTLE HANDLING FOR OPTIMUM QUALITY

10
TONS PER
HOUR

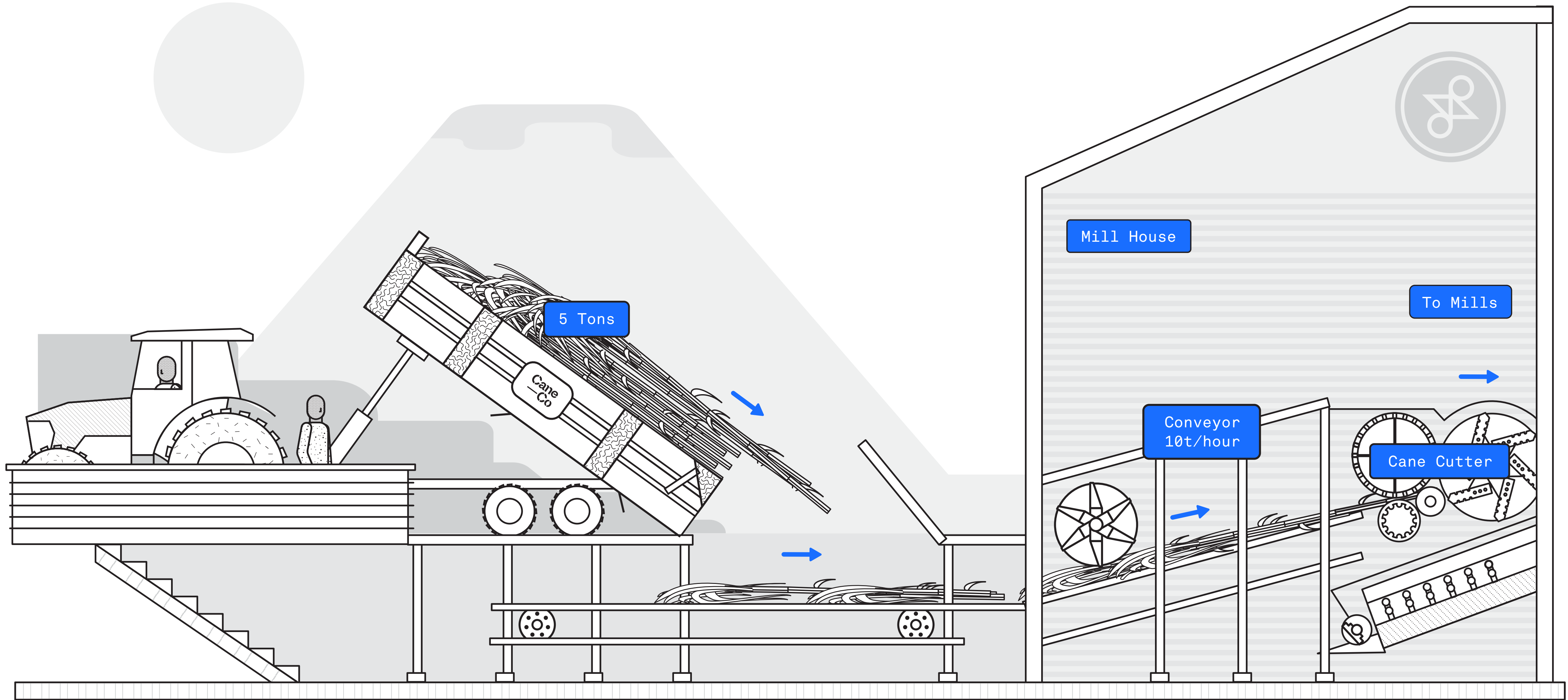

MILLING

THE MILL FROM BRAZIL

3
MILLS

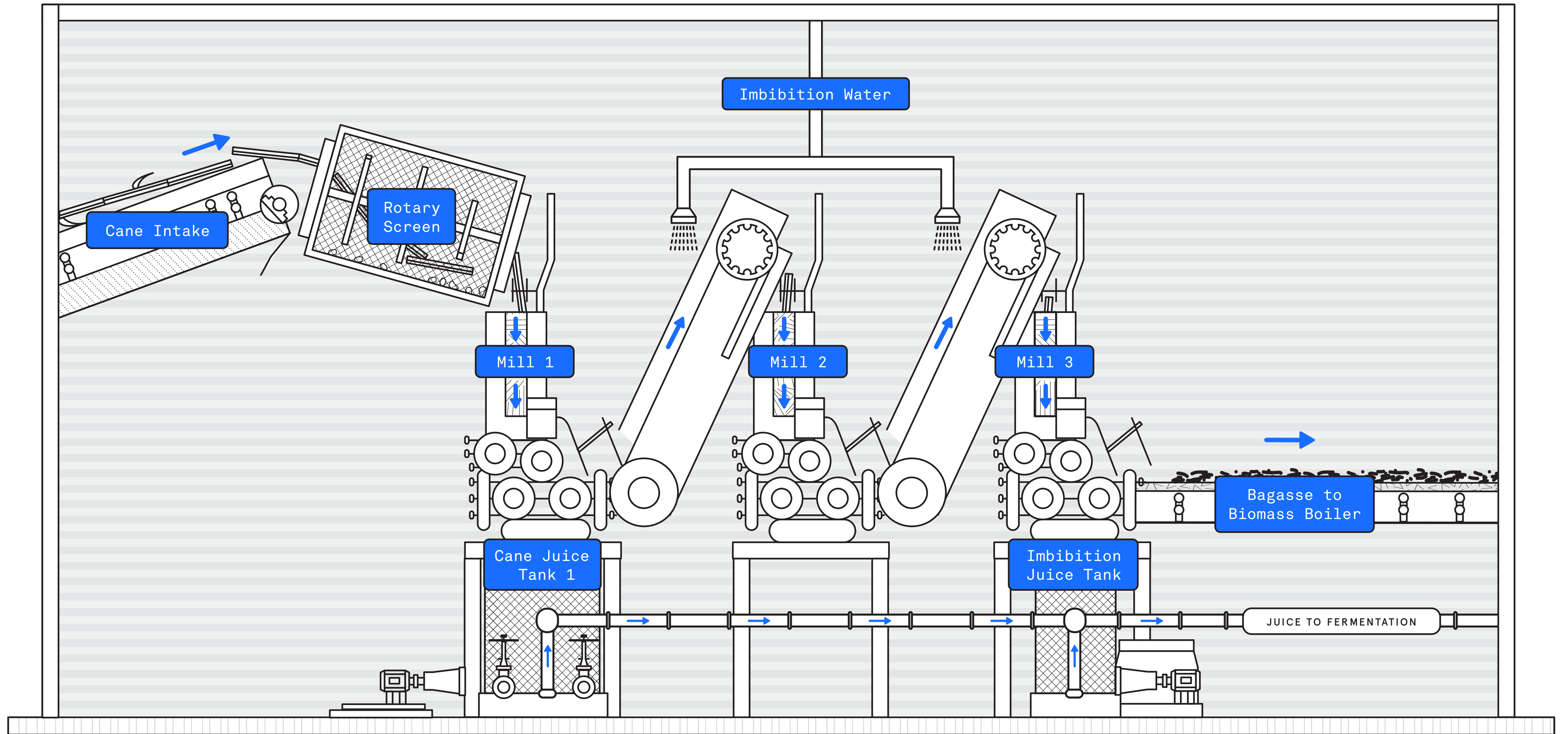

POWER

BIOMASS CLEAN AND GREEN SELF POWER GENERATION

<50
MG/Nm³

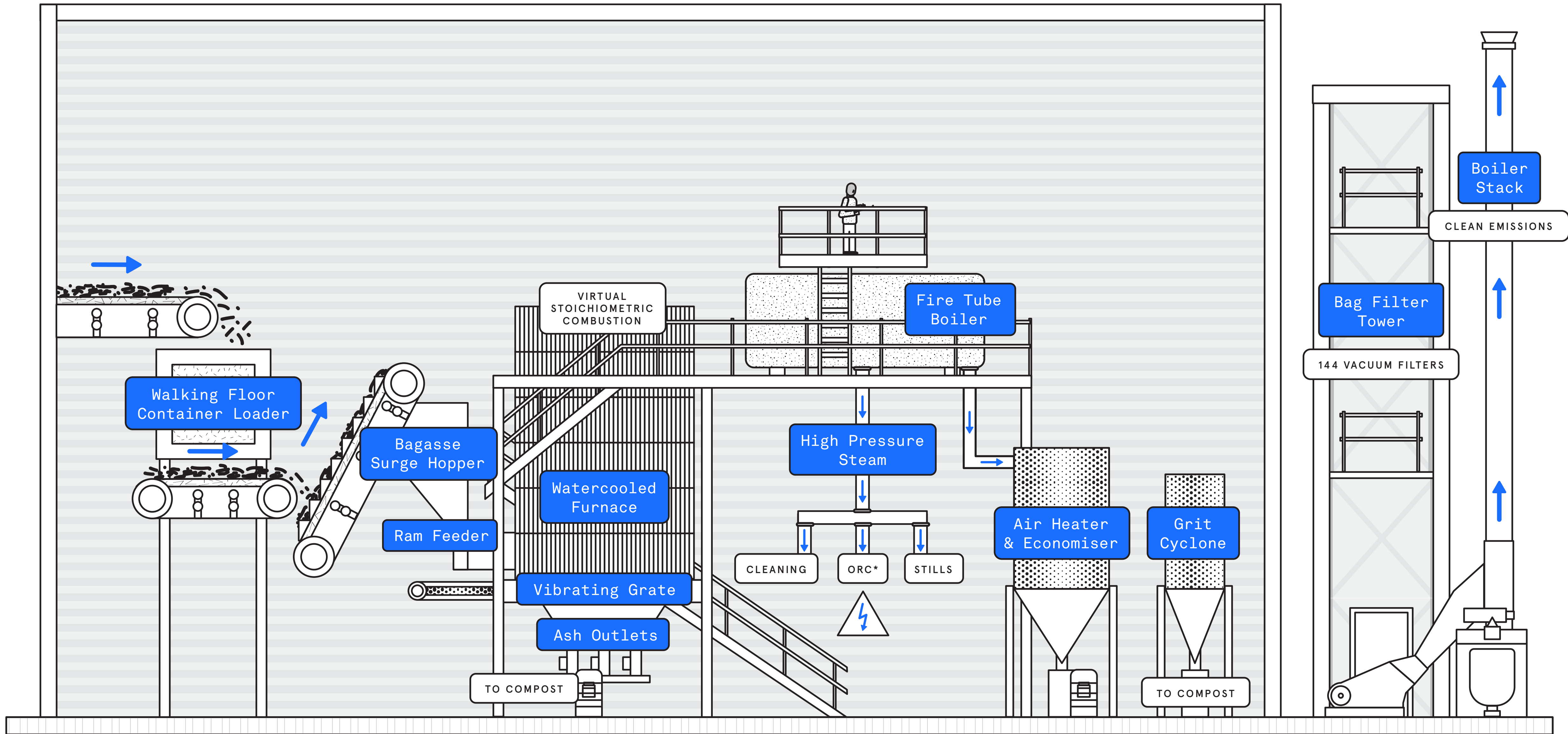

*ORC - Organic Rankine Cycle (electricity generation)

FERMENTATION

TWINNED WASHBACKS FOR FIELD FLEXIBILITY;
HORIZONTAL FOR OPTIMAL FERMENTATION

2
WASHBACKS
PER FIELD

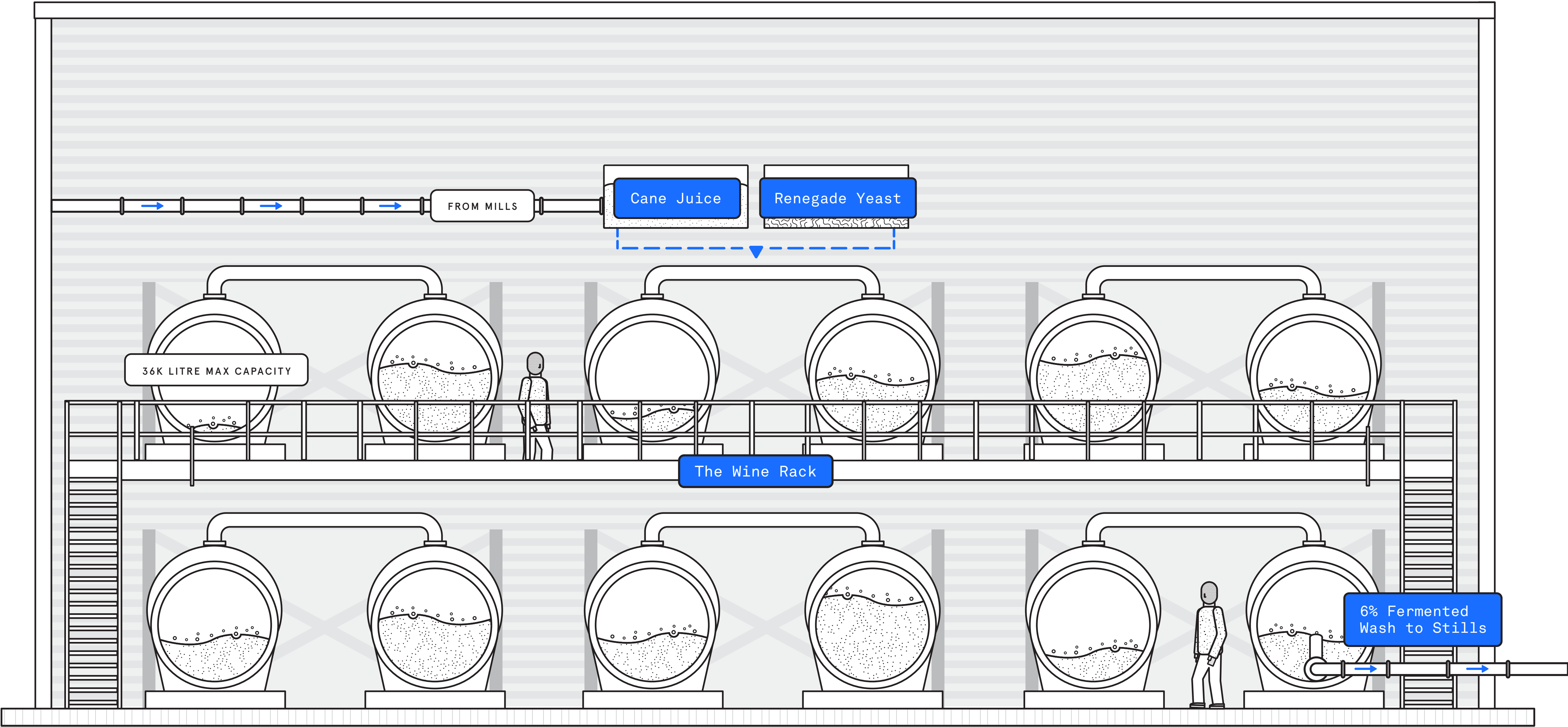

DISTILLATION

A NOD TO THE PAST WITH THE ADAM POT STILL,
AND A LOOK TO THE FUTURE WITH THE LATEST COFFEY STILL

2
STILL TYPES

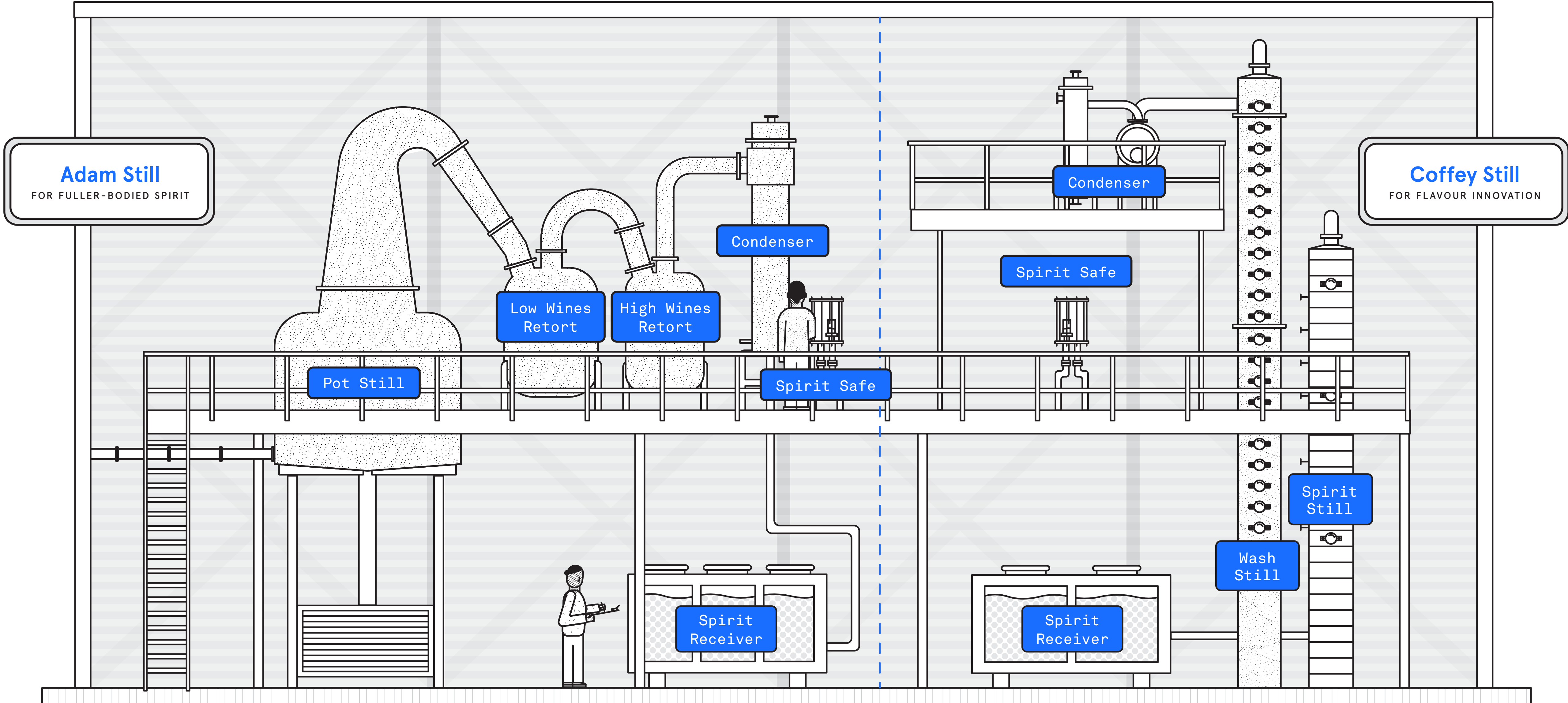

ADAM STILL

TRADITIONAL (INVENTED 1801) CARIBBEAN POT STILL FOR FULLER-BODIED SPIRIT

80%
ABV

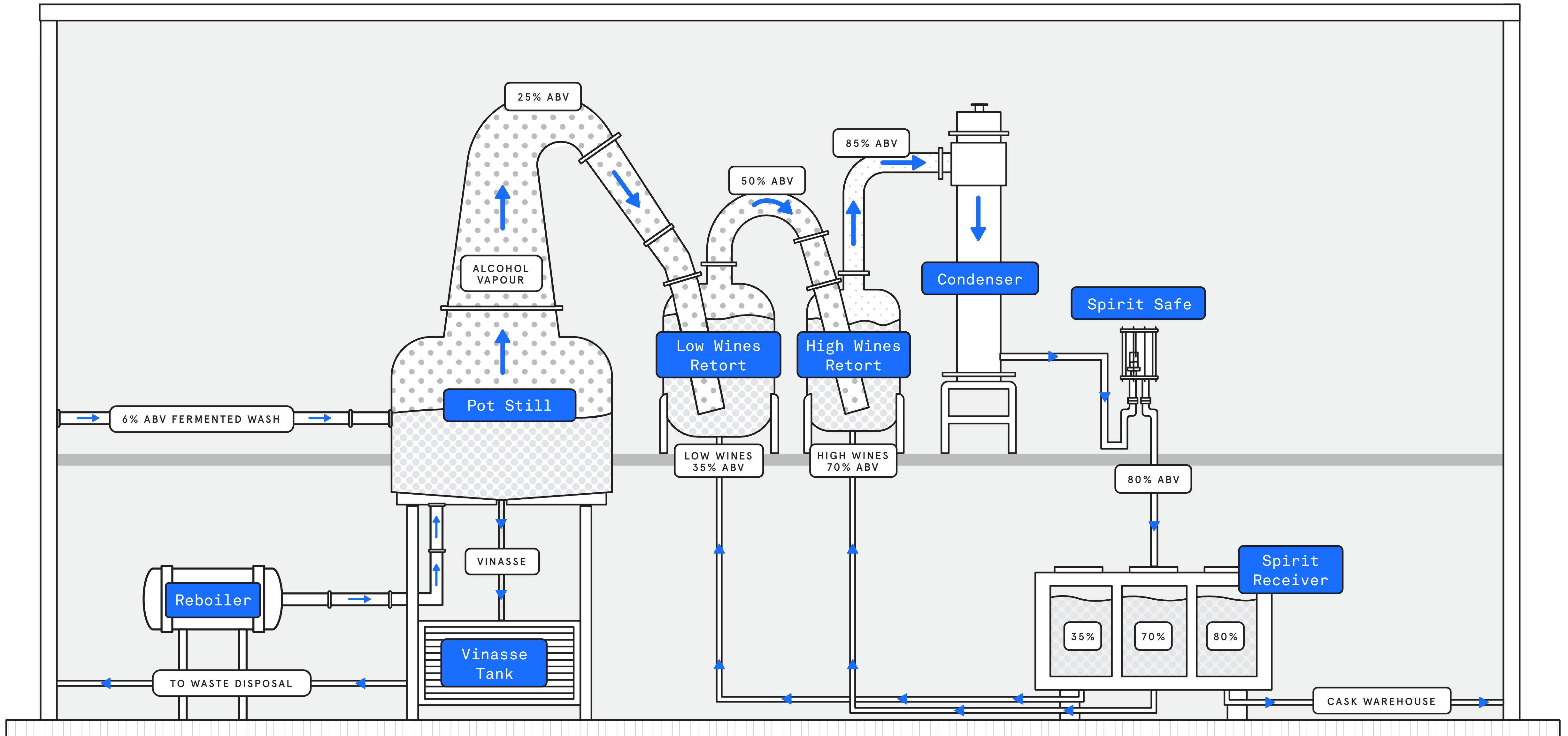

COFFEY STILL

MODERN INTERPRETATION OF COFFEY'S COLUMN STILL

8
SPIRIT TAKE OFF POINTS

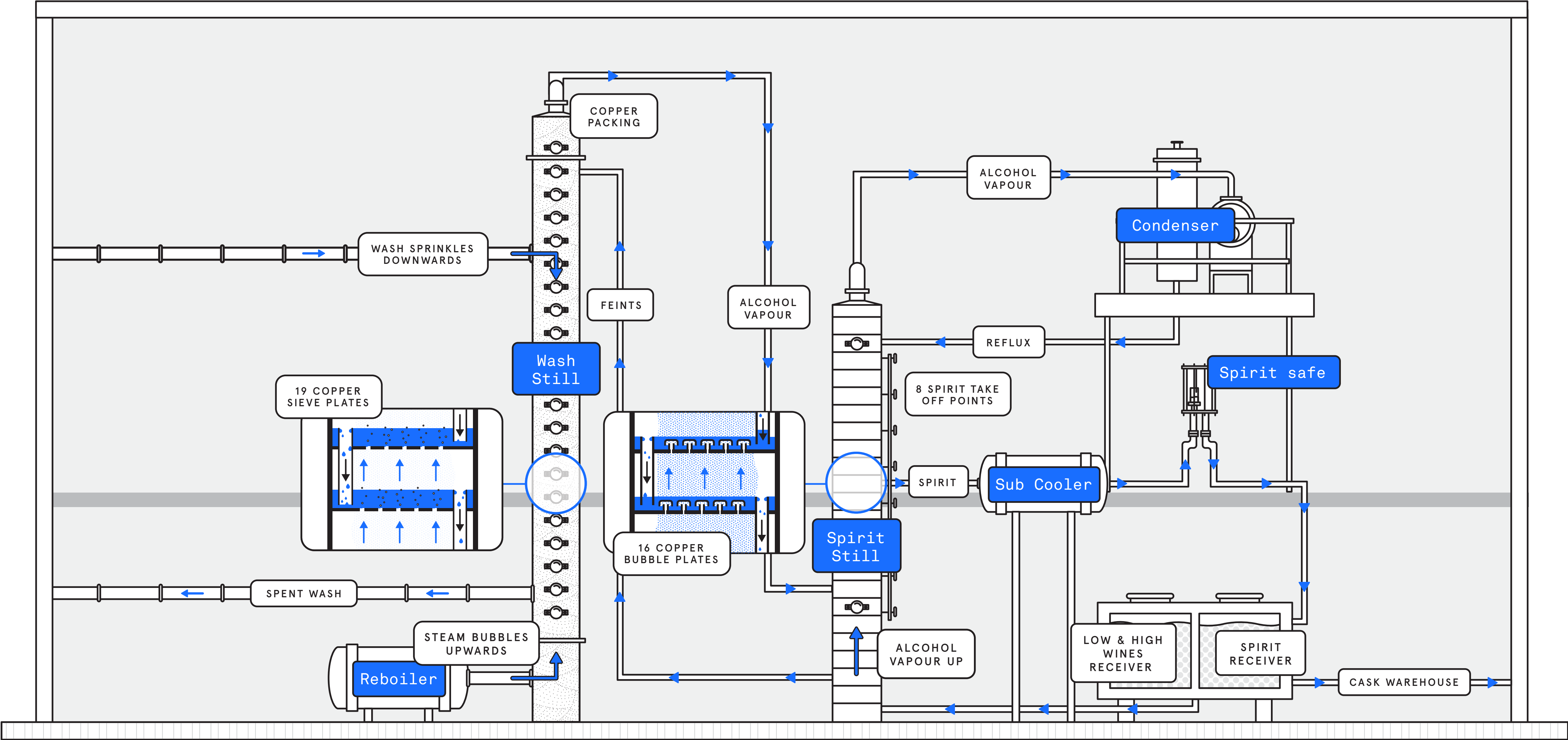

VINASSE

PHYTOREMEDIATION - PLANTS & SOIL
MAINTAIN ECOLOGICAL EQUILIBRIUM

30
DAYS

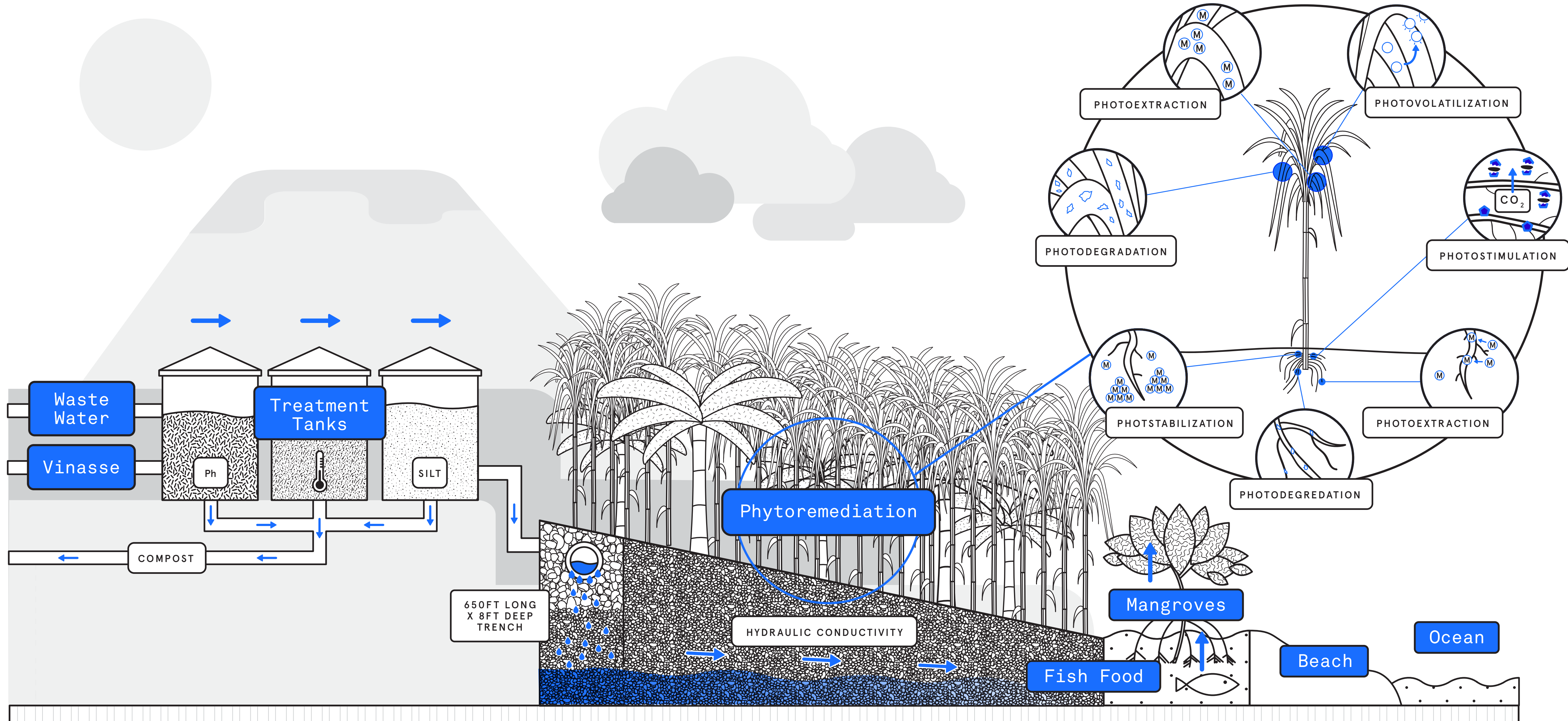

MATURATION

CARIBBEAN MATURATION PLUS PREMIUM
QUALITY OAK MEANS ADVANCED MATURITY

3
YEARS

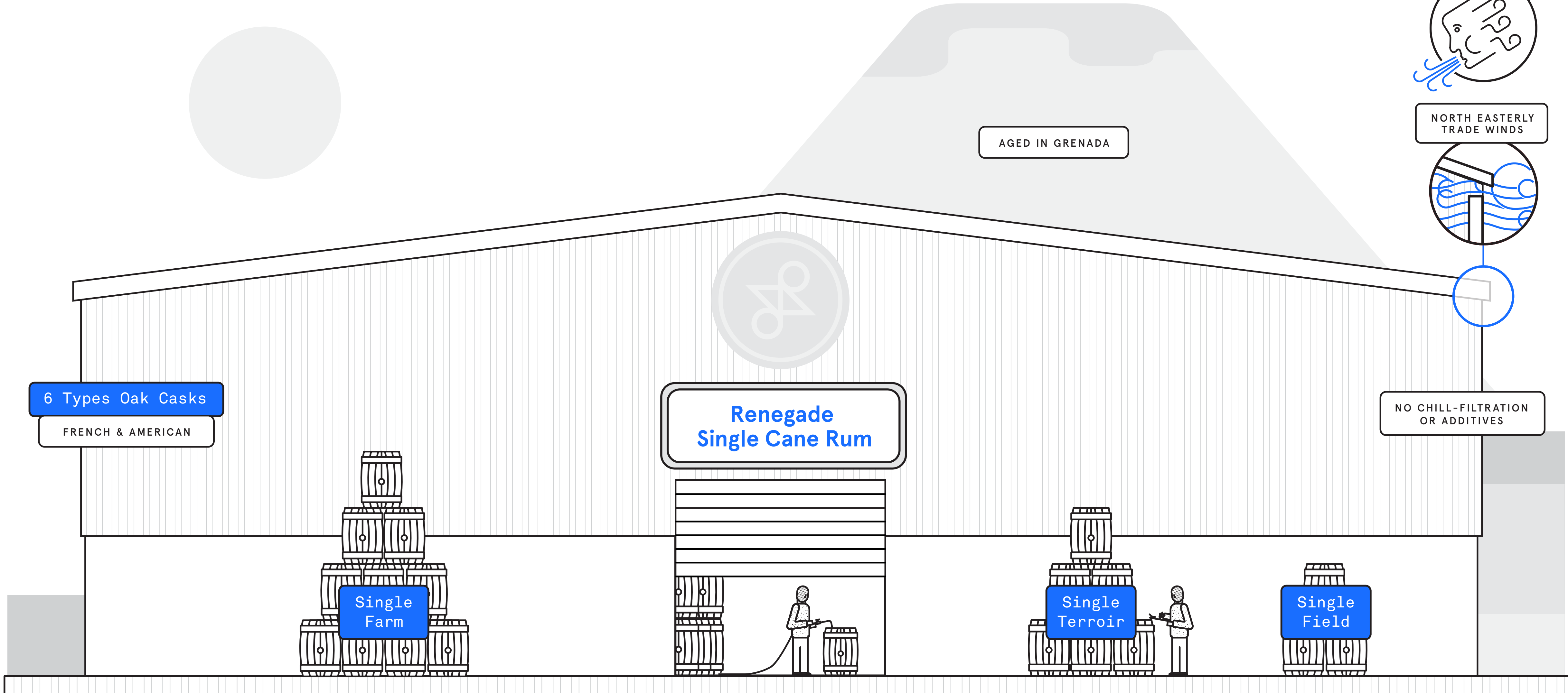

AGED IN GRENADA

6 Types Oak Casks
FRENCH & AMERICAN

Single Farm

Renegade
Single Cane Rum

Single Terroir

Single Field

NO CHILL-FILTRATION
OR ADDITIVES

NORTH EASTERLY
TRADE WINDS

$$\text{PROVENANCE}^2 = \frac{[\text{TERROIR} + \text{TRACEABILITY}]}{\text{TRANSPARENCY}}$$